

Smart **ONE**

⏪ SCROLL

User Manual



The skyline is getting smarter

Scan the following QR Code for the digital PDF version of this User Manual, plus additional onboarding tools:

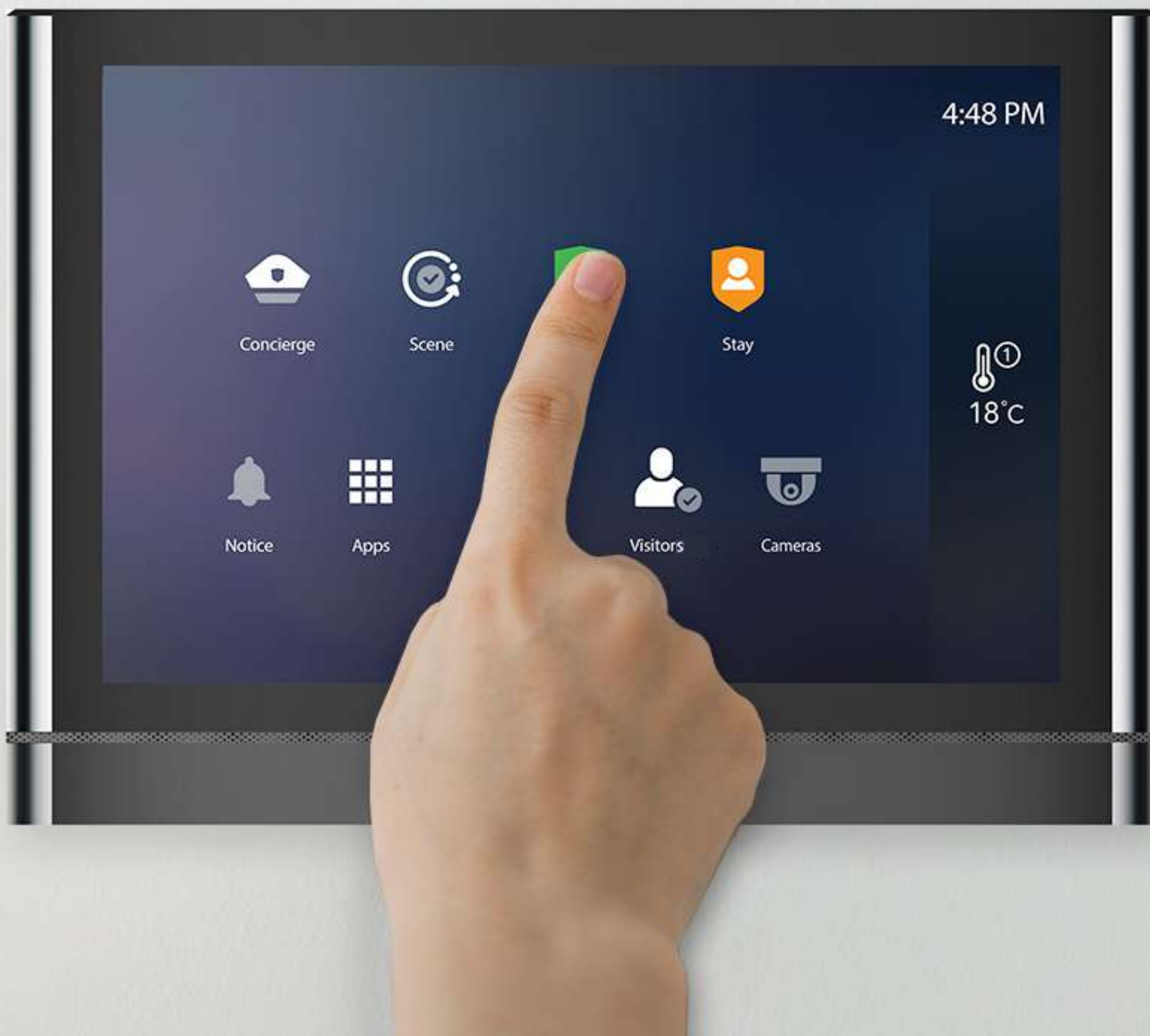
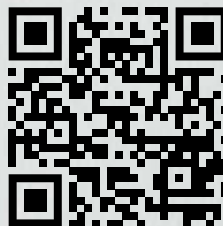

Contents

Some of the features listed below may not be available in your community at this time

1.0 Wall Pad

1.1 Overview

- ① LCD Touch Screen
- ② Speaker
- ③ Power Switch

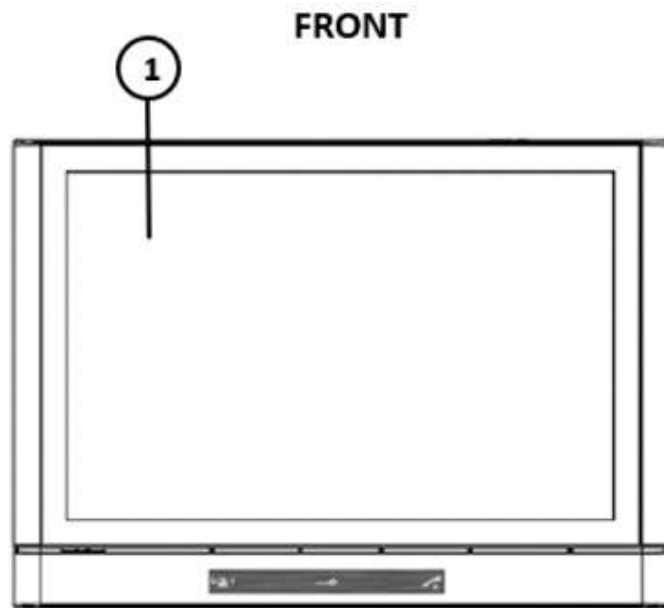

BOTTOM

1.2 Wall Pad Home Screen

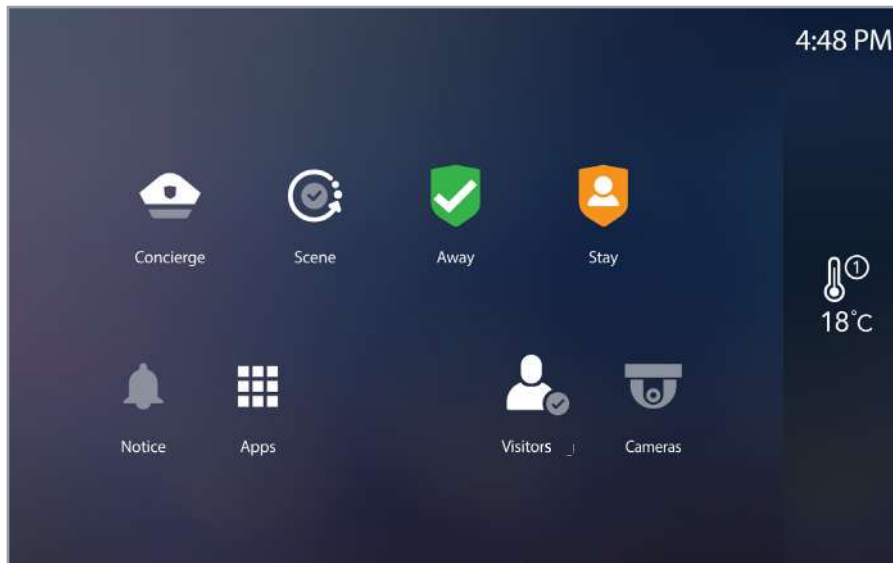

Wall Pad Home Screen



VISITORS

View and manage the captured images of visitors



CONCIERGE

Call the Concierge



AWAY

Set the 'Away Mode' security setting



STAY

Set the 'Stay Mode' security setting



NOTICE

View and manage posted notices



APPS

Installed apps



THERMOSTAT

Set and program thermostat(s)



CAMERAS

View Security Cameras within your community



SCENE

Program or activate desired "Scene"

1.3 Visitor Access

The SmartONE wall pad is designed to make managing visitor access simple and secure. With its video phone system, you can easily receive video calls from designated entrances throughout your community.

- ① Call Status
- ② Display of person calling
- ③ Volume setting
- ④ Answer call
- ⑤ Refuse call or hang up
- ⑥ Open door
- ⑦ Capture the image of the visitor

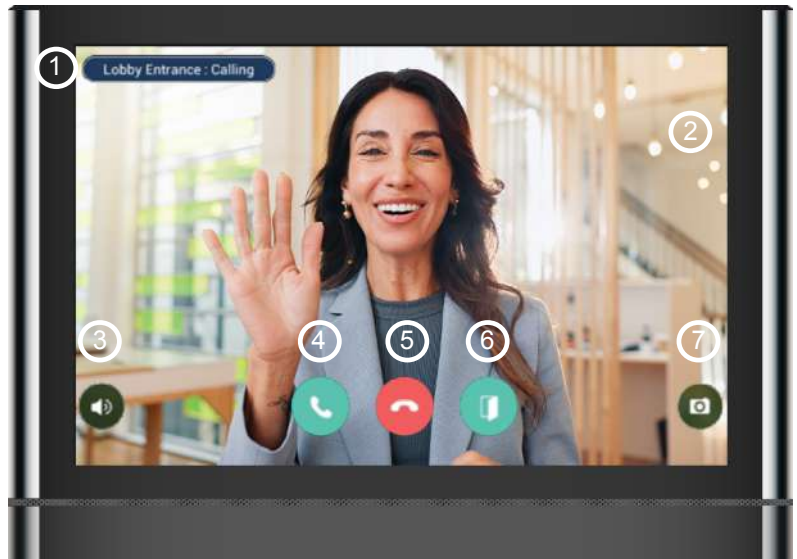

Image of person calling from entrance.

When a visitor calls your suite from the main lobby or another entrance, the wall pad will display the visitor on-screen along with the following options:

- **Location Details:** The top-left caption will display the entrance location of the call ①
- **Live Video Feed:** The main screen shows the live video feed of the visitor at the entrance ②
- **Volume Control:** Adjust the volume of the call by pressing the speaker symbol 🗣️
- **Answer Call:** Tap the green phone symbol 📞
- **End Call:** Tap the red phone symbol 📞
- **Open Door:** Tap the green door symbol 🚪
- **Capture Visitor Image:** Tap the camera symbol 📷

Captured images are stored in the Visitors, accessible via the home screen. The wall pad can save up to 128 images per suite, automatically replacing the oldest image when full. 📷

📱 Visitor calls can also appear on your ONE! App, giving you the flexibility to grant access from your smartphone with a security PIN. For help setting up or managing your PIN, please refer to page 21.

If your suite is in **Away Mode**, the system automatically captures a visitor photo when the “Capture Visitor Picture” setting is ON. These images are saved as “Missed Calls” in the Visitors.

1.4 Visitors



Access your Visitors by tapping the Visitors icon on the home screen, and easily manage and view the images of your visitors

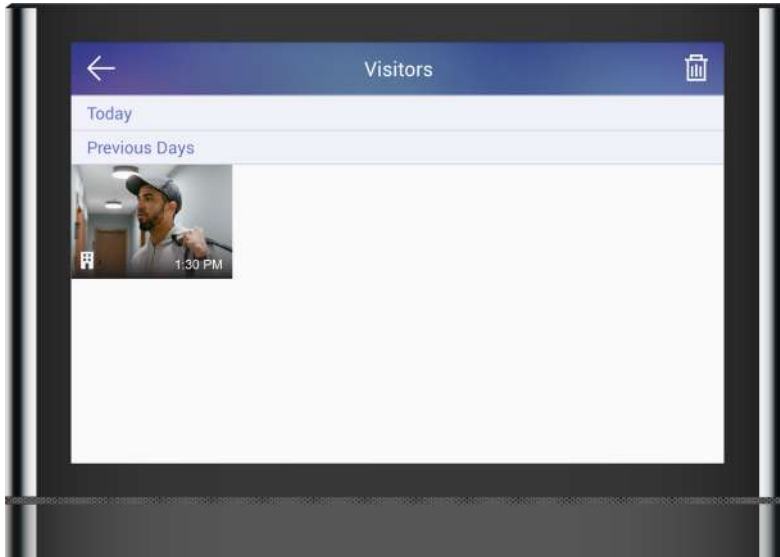



View and manage the saved images of visitors.

Viewing Recorded Images

You'll see a timestamp for images saved today, and a full date and time for those from previous days. Simply scroll down to view older images. To get a closer look, tap an image to enlarge it. Use the left and right arrow buttons to scroll through the stored images. If you'd like to remove any unwanted images, just tap the trash can icon .

Deleting Recorded Images

- 1) Tap the trash can icon to start deleting 
- 2) Select individual images or tap 'Select all' to clear the entire set
- 3) If you change your mind, tap an image again to unselect it
- 4) Once you're ready, hit the 'Delete' button to remove the selected images

 The system stores up to 128 images. Once the limit is reached, the oldest images are automatically removed to make space for new ones.

1.5 Security: Concierge (if available in your community)



Calling the Concierge



If your community offers concierge services, simply tap the 'Concierge' icon on the main screen or press the 'Concierge' button at the bottom of your wall pad to get in touch with them.

Receiving a Call From the Concierge

When the concierge calls, your wall pad will ring and display the message 'Concierge Calling' at the top left of the screen.

- To answer the call, tap the 'Call' button 
- To decline the call, tap the 'Cancel' button
- To end the call, tap the 'End Call' button 

 The concierge can't see you during a call, but you can see them.

You'll also receive the concierge call on your ONE! App, allowing you to answer or decline the call directly from your smartphone. For this, just use your phone's standard call features.

Call Switching Function

If you're already on a concierge call and someone from the lobby tries to reach you, a message will appear at the top left of the screen saying, "Lobby Calling."

To switch to the new call, tap the Switch Call  button. The previous call will automatically disconnect when you answer the new one.

1.6 Security: Suite Security and Alarm



STAY MODE

Activates the 'Stay Mode' security setting.



AWAY MODE

Activates the 'Away Mode' security setting.

1.7 Security: Setting Your Wall Pad Password

The default password for your wall pad is '1234'.

For your security, it's important to change this password right away. Follow the steps in the provided [link](#) to set a new password. Alternatively, you can see how to change your password in section [1.19](#).

⚠ Note: If you're unable to unlock your wall pad with the default password, please contact support.

1.8 Security: 'Away Mode' Security Setting



The **Away Mode** icon is your go-to when you're leaving your suite and want the security alarm activated. Once **Away Mode** is set, the home screen will reflect your suite's secure status, as shown below.

Look for the green indicator circle at the bottom of the screen, signaling that your suite is in **Away Mode**. You can also set **Away Mode** directly from your **ONE! App** by pressing the **Away Mode** icon.

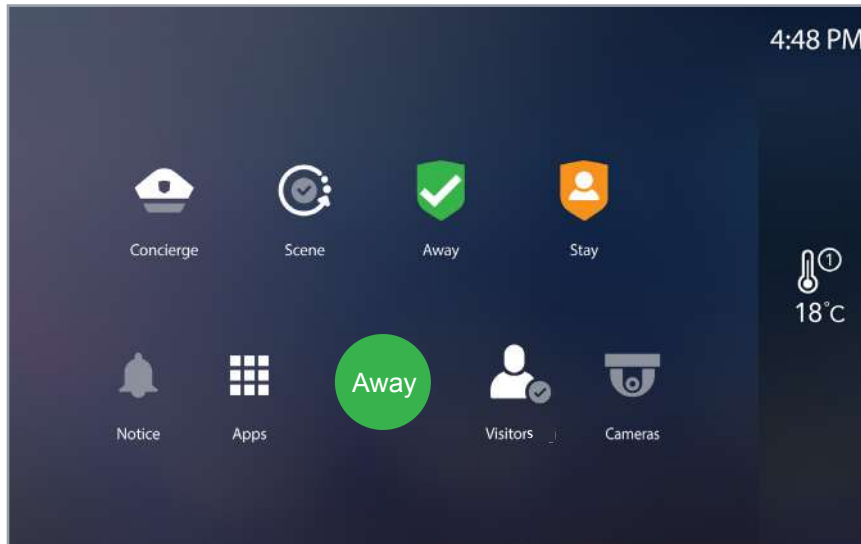

Security Set to Away Mode

What Happens When You're In 'Away Mode'?

With **Away Mode** activated, your suite's thermostat(s) will automatically adjust to the preset **Away Mode** temperature. For more details on setting the **Away Mode** temperature, refer to [section 1.18](#). Additionally, **Away Mode** will trigger automatic photo capture of any visitors at selected entrance areas.

You can fine-tune your security preferences by adjusting alarm settings, such as how long the alarm takes to activate after you leave and how much time you have to deactivate the alarm upon your return. This can all be managed in the **Alarm Settings** screen in [section 1.16](#).

Returning Home After 'Away Mode' Is Set

When you return home and your suite is in **Away Mode**, the wall pad will play a friendly audible jingle to let you know the security alarm is on. Simply touch the wall pad and select **Dismiss** to deactivate the alarm. The **Dismiss** button will bring up the alarm password screen – enter your four-digit password to deactivate.

- ⚙️ Note: The **default password** for your wall pad is '1234'. Please see this [link](#) for instructions on changing your wall pad password. Alternatively, you can see how to change your password in section [1.19](#)



Password Entry Screen to Dismiss the Alarm

- ⚙️ If the password isn't entered within **20 seconds** or if three incorrect attempts are made, the suite alarm will sound.

1.9 Security: ‘Stay Mode’ Security Setting



The **Stay Mode** security setting is ideal when you’re at home and want the security system to stay active. When **Stay Mode** is engaged, the home screen will reflect your suite’s security status, as shown below. Look for the **orange indicator circle** at the bottom of the screen, signaling that your suite is in **Stay Mode**.

You can easily set **Stay Mode** from your **ONE! App** by pressing the **Stay Mode** icon.

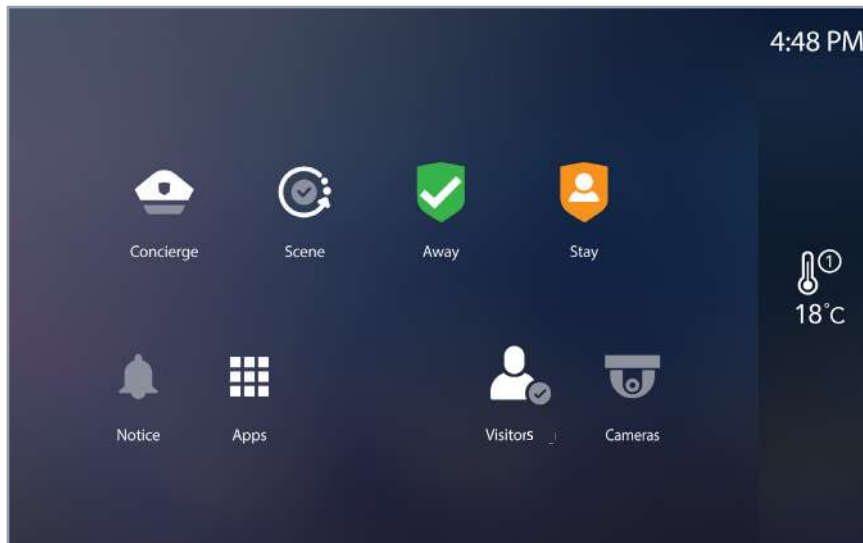

Security Set to Stay Mode

What Happens When You’re in ‘Stay Mode’?

In **Stay Mode**, your suite’s thermostat(s) will maintain the current temperature settings. If your suite has motion sensors integrated into the alarm system, these will be bypassed, allowing movement within the suite without triggering the alarm.

What happens if The Suite Entry Door is Opened in ‘Stay Mode’?

If the suite entry door is opened while the suite is in **Stay Mode**, the alarm will sound immediately, notifying all paired smartphones and the concierge.

1.10 Security: Dismissing The Alarm

When the suite is in **Alarm Mode**, all paired smartphones will receive notifications, as will the concierge station.

To stop the alarm, simply press the **Deactivate** button located at the bottom of the emergency screen on the wall pad. You'll then be prompted to input your four-digit password to dismiss the alarm.



Suite Emergency Screen

 Note: The default password for your wall pad is '1234'. Be sure to change your password following the instructions in this [link](#). Alternatively, you can see how to change your password in section [1.19](#).

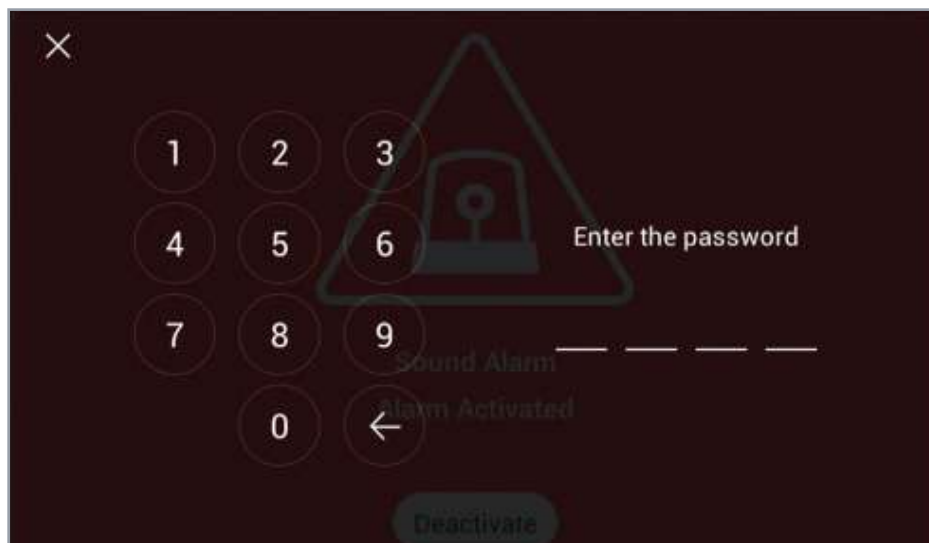

Password Input to Deactivate the Suite Emergency Alarm

1.11 Notices



The Property Management Team can send community notices directly to your in-suite wall pad. The **Notice Icon** on the home screen displays a counter to show the number of new messages you've received. Tap the icon to open the notice screen, where you can select an individual notice to view and mark as read. You can also delete notices by selecting the message and pressing the **Trash Can Icon** .

Notices can be viewed and deleted from the **ONE! App** as well.

Notice	
Elevator Repair	09:30 PM
Check all facilities	04:30 PM
Fire Protection Inspection	04:00 PM
Check security facilities	2016.03.20
Electrical wiring work	2016.03.20

Notice Screen

1.12 Cameras



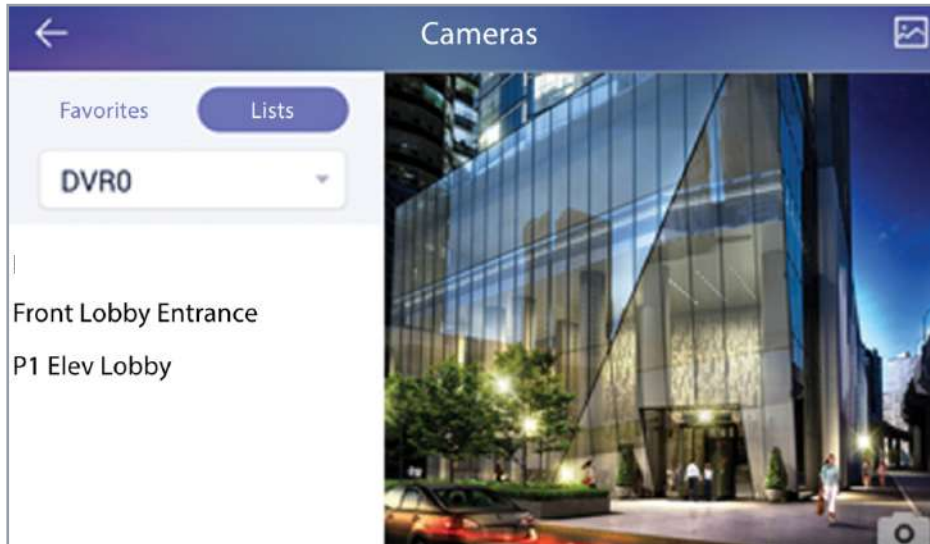

The camera screen allows you to view designated cameras throughout your community, keeping you informed and secure.



View and manage the saved images of visitors.

On the left side of the screen, you'll find a list of available cameras. Simply press a camera's name to view the feed. When you select a camera, its live image will appear on the main screen.

If you notice any suspicious activity, you can capture an image by pressing the Capture Icon  at the bottom right of the screen.

To review captured images, tap the image icon  located in the top-right corner. This will open the captured images screen, where you can easily scroll through and manage the photos.

1.13 Reviewing Photos

To browse your image collection, click any image listed on the left to view it in full on the right. To delete an image, click the Trash Can Icon  on the selected image.

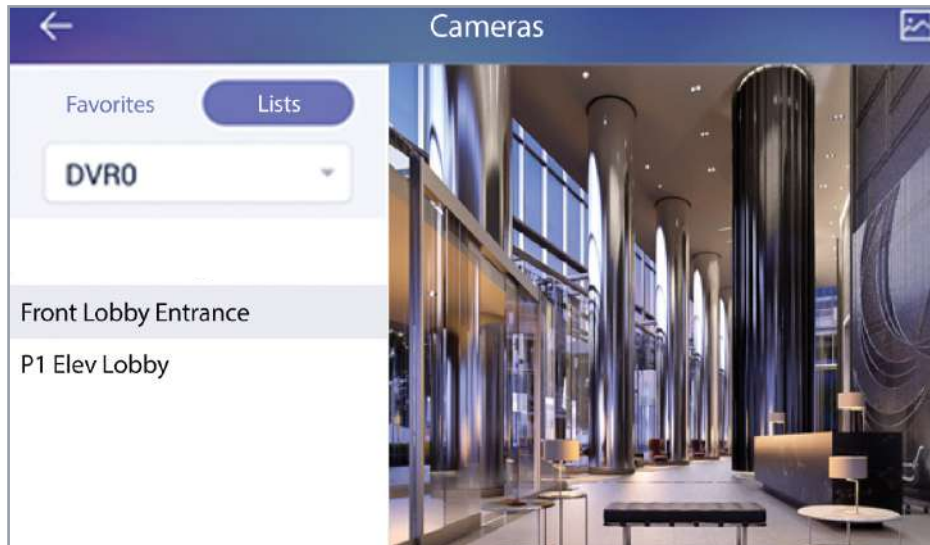

Review and Manage Captured Images

 Note: While you can view cameras from your **ONE! App**, the image capture function is only available on the wall pad. All captured images will count toward your **suite's total image limit of 128**.

1.14 Apps



The Apps Screen is where you'll find your settings menu and other helpful applications. You can easily navigate between screens using the **Home** and **Back** buttons located on your wall pad.

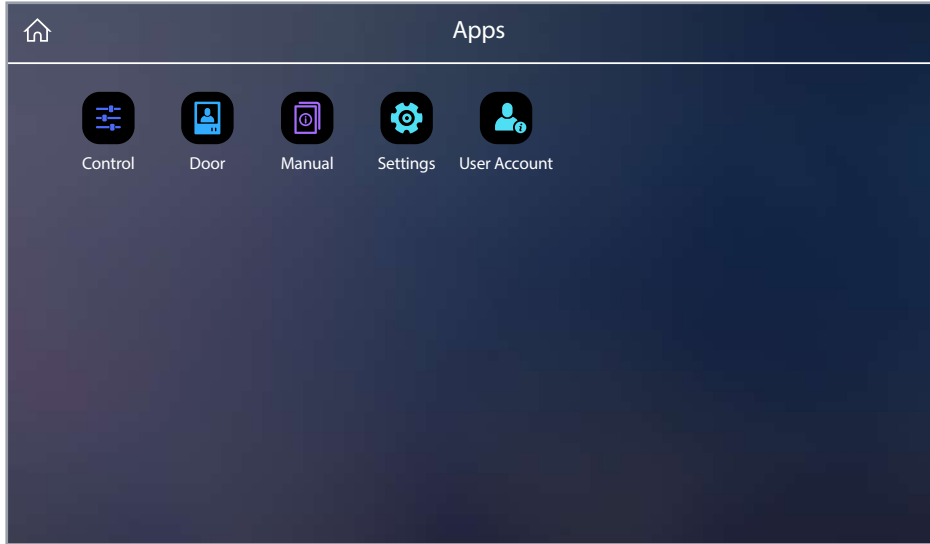

Apps Screen

1.15 Sign Up – Registering Your Smartphone to Your Suite and Door Lock

Step 1: Get the ONE! app

To begin, download the **ONE! App** from the **Apple App Store** or **Google Play Store** by searching for “**SmartONE Solutions.**” The app is compatible with most **Android** and **iOS** platforms.



Step 2: Open the ONE! app

1. Create a user account by filling in the required information
2. Review and accept the **Privacy Policy** and **Terms and Conditions**
3. You'll receive a confirmation email.
Follow the instructions to verify your email.
4. Once verified, log in with the email address and password you just created.
5. Upon logging in for the first time, follow the onboarding instructions on the ONE! App to complete your registration.

- 🔗 Scan the QR code on your wall pad as per the instructions above.

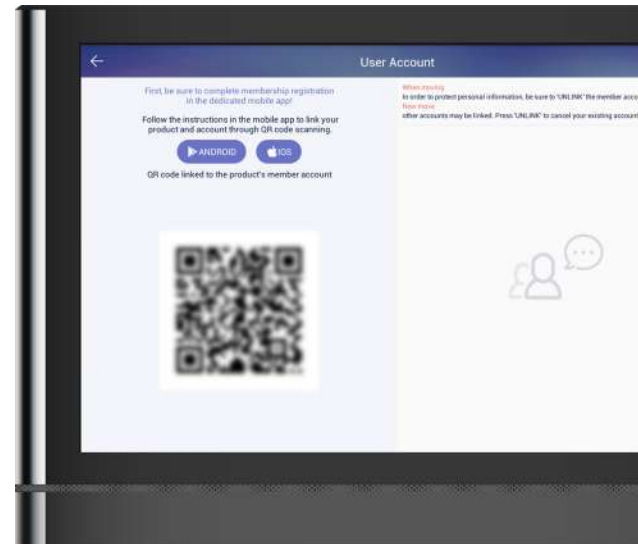

1.16 Settings

To access the Settings menu from the wall pad home screen, click on **Apps** → **Settings**.

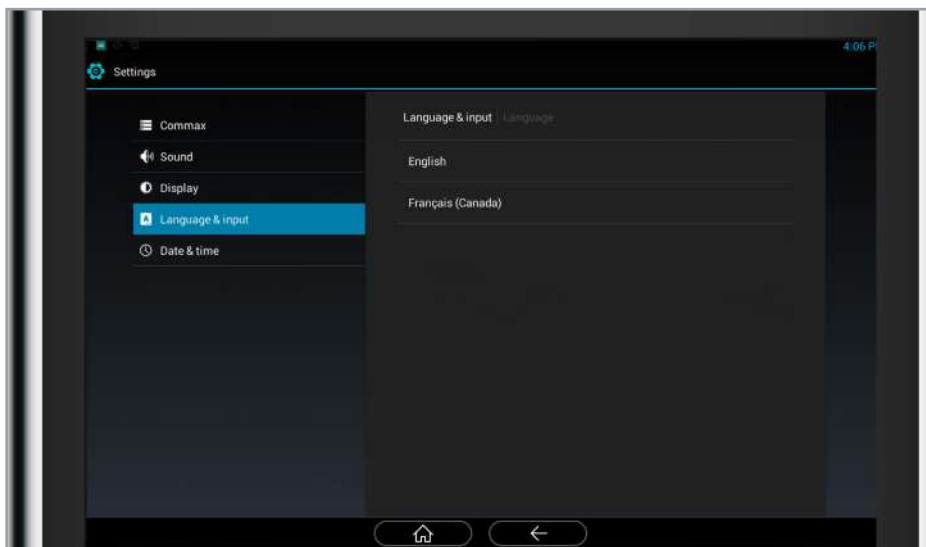

Settings User Configuration

Reset User Data

This function is designed to clear the system when a resident moves out and a new person moves in.

It will:

- Clear any saved pictures stored on the wall pad
- Reset the security password to '1234'

To do this, click on **Apps** → **Settings** → **Commax** → **User Configuration** → **Reset User Data**

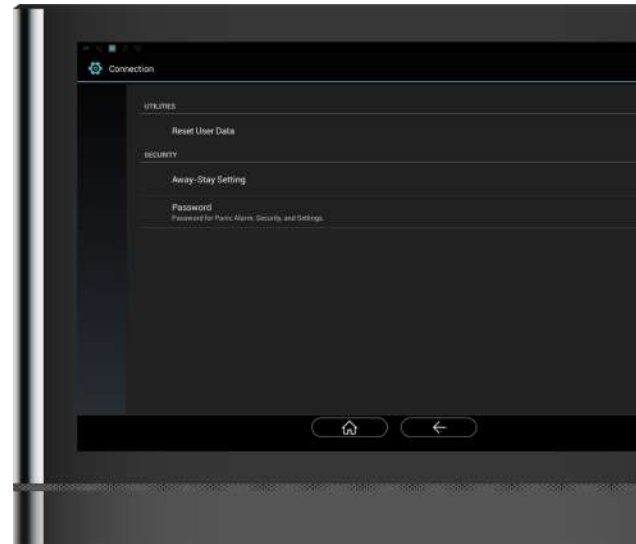
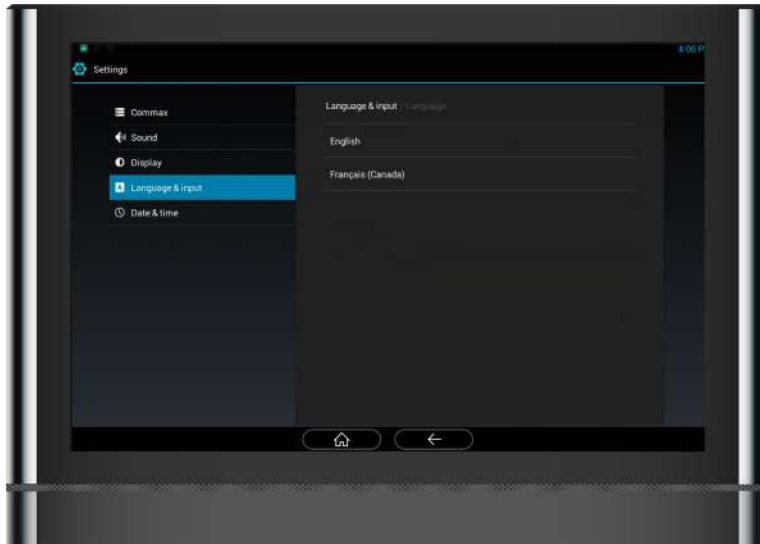

To disconnect all paired smartphones, click on Apps -> User Account and click the Unlink button next to each device.

Change Language Settings

To change the language settings on your wall pad, follow these steps:

1. On the wall pad home screen, click on **Apps** → **Settings**

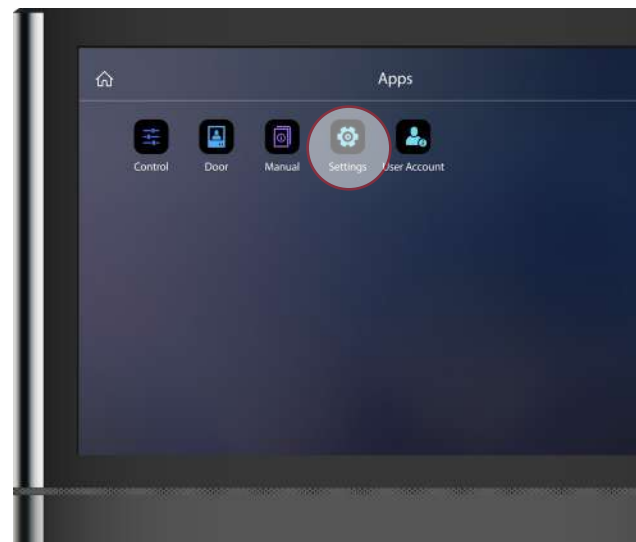
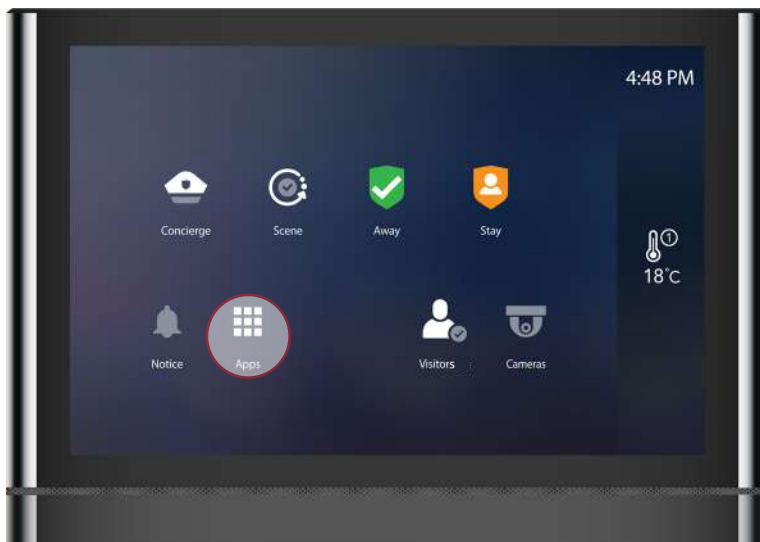

2. On the **Settings** page, select **Language & Input**, then click **Language** at the top of the screen

⚠ Note: The remaining menu options are not functional for residents.

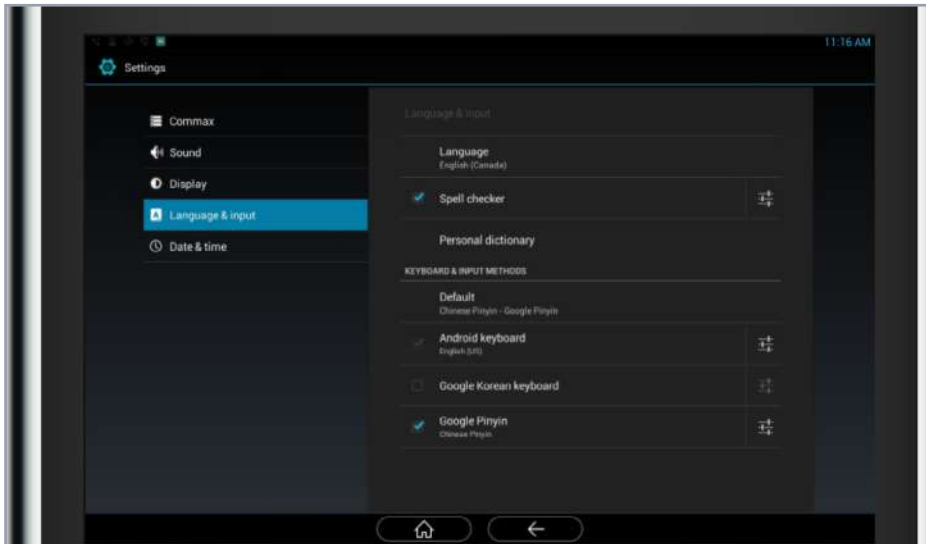

Language Settings

3. From the **Language** page, you can change the language setting for your wall pad.

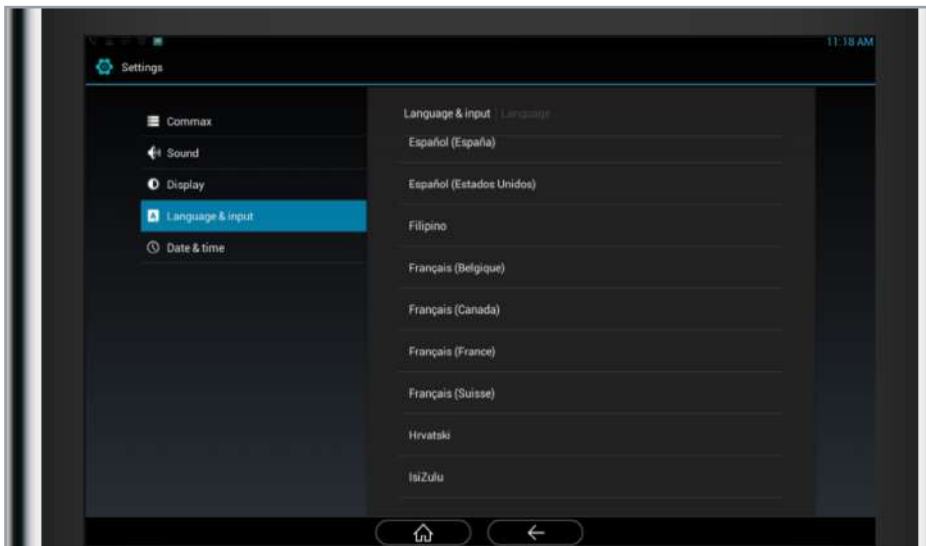

⚠ **Important note:** only **English** and **French** are supported. If you select another language, only a limited number of menu items will be translated. You'll need to change it back to English or French to ensure full functionality.

1.17 Security: Away-Stay Setting

This setting allows you to adjust the alarm-related preferences for your suite.

To access it from the home screen of your wall pad, click on **Scene** → **Scene Detail**.

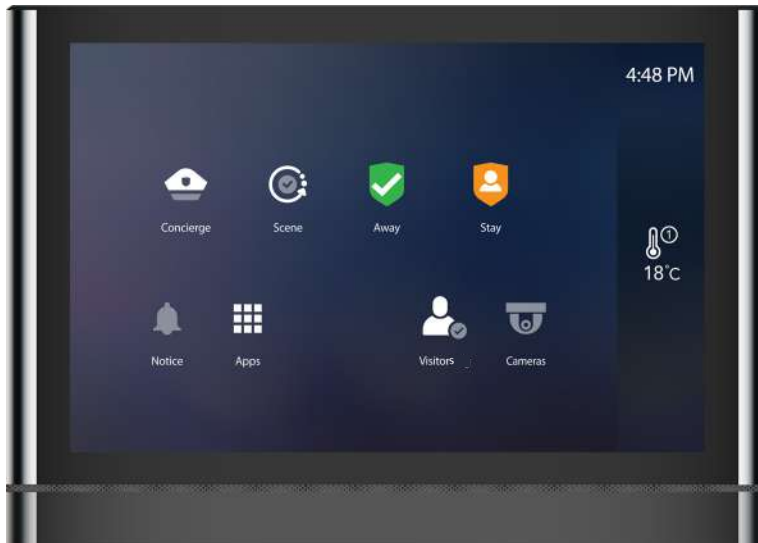

You'll then be directed to the following screen as shown below. You can then modify the settings or activate the security system by pressing the **Edit** and **Run** buttons on the left side of the screen.

Descriptions of Settings:

- **Going out delay:** This setting defines the amount of time between activating the alarm and when it becomes active. It allows you time to leave your suite before the alarm is triggered.
- **Returning delay:** This gives you a grace period to deactivate the alarm after it's triggered, before it starts sounding.
- **Sensor1 – Front Door Sensor:** This controls the sensor at your suite's front door. You can turn it off to disable the door sensor.
- **Sensor3 – Additional Motion Detectors:** If your suite is equipped with motion detectors, this option allows you to manage those sensors.
- **Save visitor photos:** When this setting is ON, a photo of a visitor at the lobby entrance will automatically be captured when Away Mode is activated. This allows you to see who visited while you were away.

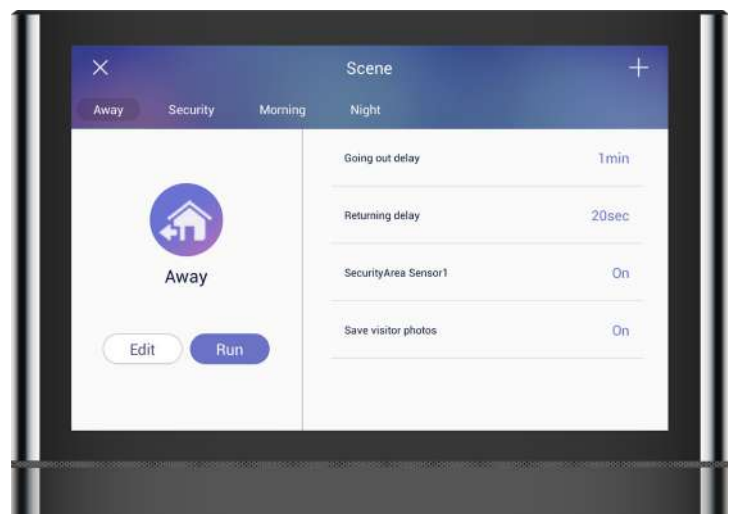

1.18 Thermostat



- ⚙️ If your suite is integrated with HVAC thermostat controls, here's how to manage them:

You can access your thermostat(s) by pressing the Thermostat icon on the right edge of the home screen. The temperature displayed on the icon represents your current suite temperature. If you have multiple thermostats, each one will have its own icon, and you can adjust each thermostat independently. The thermostat settings screen is shown below.

- ⚙️ **Note:** The interface may vary based on your community's HVAC system

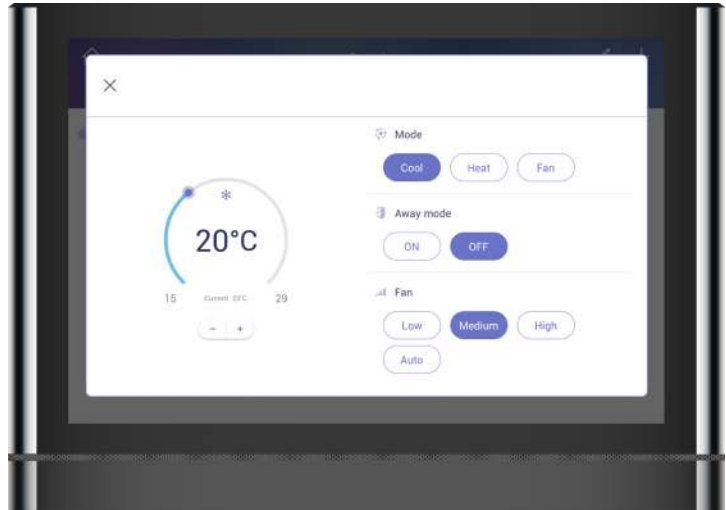

Thermostat Interface

Key Features:

- Away Mode Control:** When Away Mode is activated, you can set a desired temperature for your suite. This helps save energy when you're not home. When Away Mode is turned OFF, normal thermostat operation resumes.
 - Cooling, Heating, or Fan Mode:** Choose between **Cool, Heat, or Fan** functions by selecting the corresponding button on the thermostat screen.
 - Temperature Adjustment:** Use the - and + symbols or the sliding control ring to adjust the temperature
 - Fan Speed Control:** Adjust the fan speed by selecting **Auto, Low, Med, or High**. The Auto setting automatically adjusts the fan speed for optimal performance, but you can manually select a speed to override it.
- ⚙️ The availability of certain features may vary depending on your building's HVAC system requirements. Some suites may use a two-pipe HVAC system, meaning the heat function is available only in winter, and the cool function is available only in summer. If there is no OFF icon, you will not be able to turn off your HVAC system. For more details, consult your property manager.

1.19 Security Password

To change your suite alarm password please follow these instructions:

1. From the home screen, select the **Apps** menu
2. Go to **Settings** → **User Configuration** → **Password**
3. Enter a new four-digit password twice to confirm your new security code
4. Hit save.

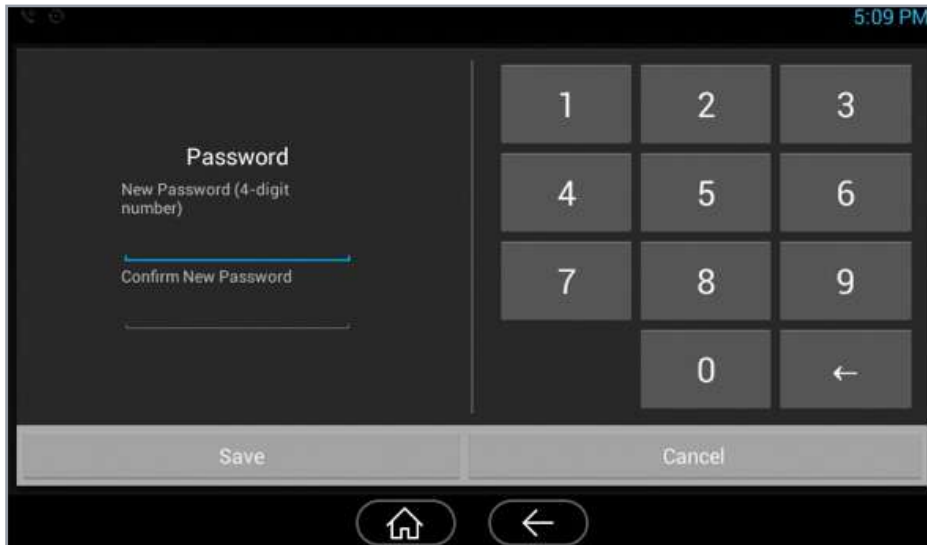

Security Code Entry Screen

1.20 Touch Pad Sensitivity

You can adjust the sensitivity of the touch pad through the following steps:

1. Go to **Settings** → **Commax** → **Touch Pad Sensitivity**.
2. Selecting this option will display the sensitivity settings screen.
3. Hit save.

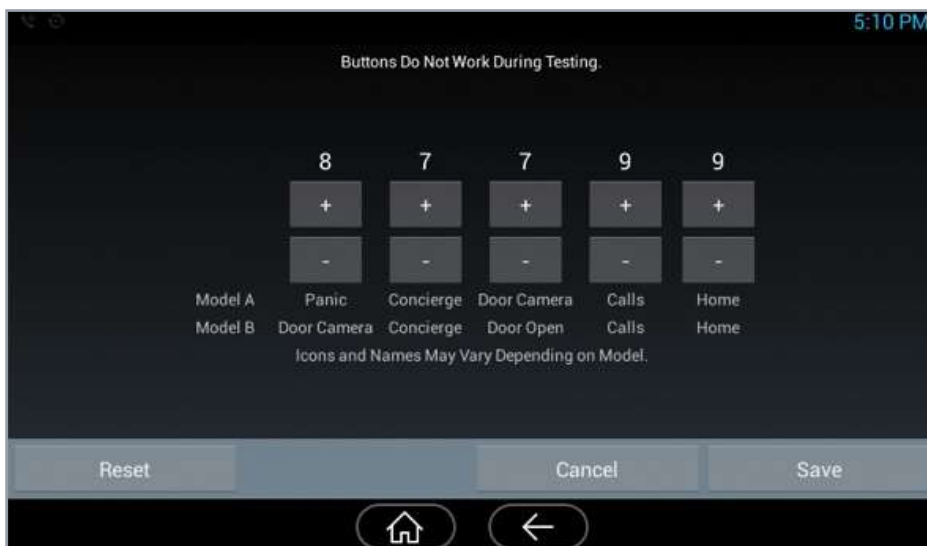

Touch Screen Sensitivity Adjustment

Note: Touch screen sensitivity increases as the sensitivity number decreases.

2.1 Overview

The ONE! App is your all-in-one solution for simplifying life in a smart community. It connects you to your home and community, making everyday tasks more seamless and enjoyable. Whether you're managing your suite's settings, booking amenities, or staying informed about community updates, the ONE! App keeps everything at your fingertips.

With features like Stay and Away modes for security, smart home controls, amenity booking, and community announcements, the app helps you manage your daily routine with ease.

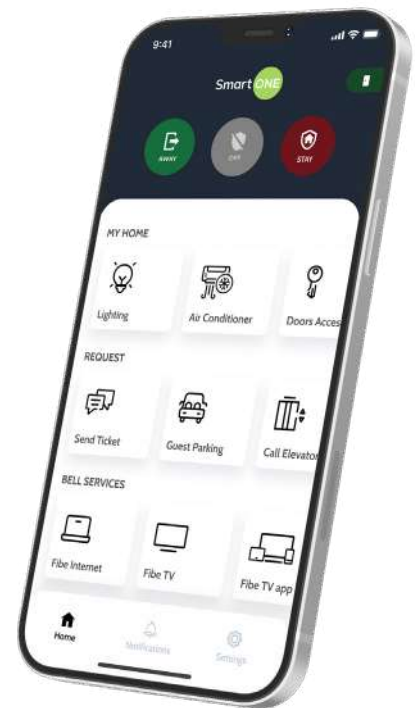

How the ONE! App makes your life easier:

- **Simplified Controls:** Adjust your lighting and temperature effortlessly through a single, intuitive interface.
- **Streamlined Amenity Booking:** Book common spaces and amenities quickly and easily, with just a few taps.
- **Stay Connected:** Keep up with community news and events through announcements, helping you feel more engaged and in the loop.
- **Enhanced Security:** Whether you're home or away, manage your suite's security settings with confidence using Stay and Away modes.
- **Personalized Living:** Create a home environment that matches your lifestyle with customizable settings like Scenes, giving your space a truly personal touch.

With the ONE! App, your living experience is smarter, more convenient, and designed entirely with you in mind.

2.2 Access Control

Access control provides quick and easy access to your building, with the added convenience of scheduled entry through Amenity Booking Access Requests, ensuring a smooth and tailored experience for you.

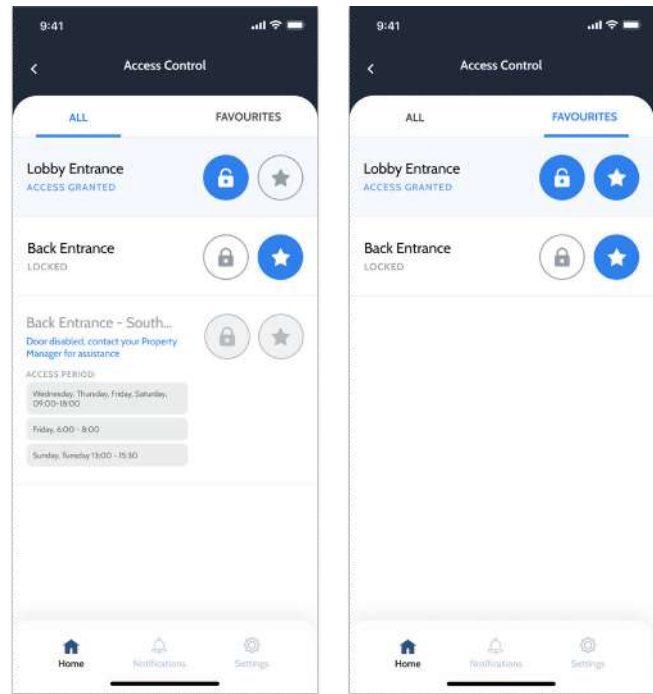

2.3 Suite Access Featuring the Digital Door Lock

This feature allows you to remotely unlock your suite's door directly from the ONE! App.

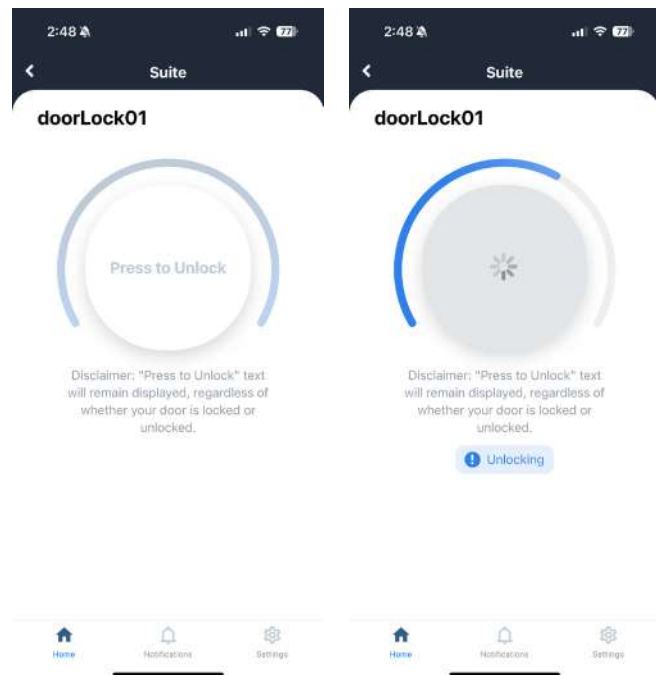

2.4 Thermostat

The thermostat feature gives you complete control over your suite's temperature, making it easy to create a comfortable environment.

To access your suite's thermostat, simply tap the Thermostat icon on the ONE! App home screen. The displayed temperature shows the current ambient temperature of your suite. If your suite has multiple thermostats, each will be represented by its own icon, allowing you to adjust temperatures independently for different areas.

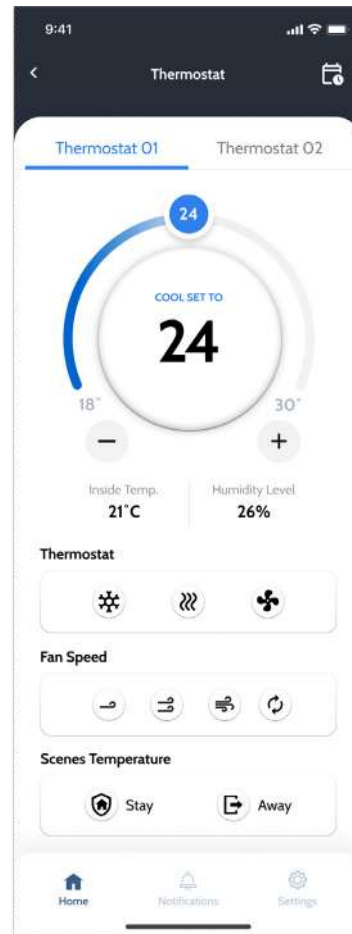

When the Wall Pad is connected to your community's HVAC system, it generates a unit name for each board (e.g., FCU01, FCU02). Only one temperature is displayed at a time on the ONE! App, Wall Pad, or Thermostat.

When Away Mode is activated, the thermostat automatically switches to 'Away' mode, adjusting the temperature to the preset value for energy efficiency and convenience.

⚠ Keep in mind that the interface may vary depending on your community's HVAC system.

Additionally, you can adjust the temperature directly from the Wall Pad, offering another way to control your suite's comfort.

2.5 Suite Security and Alarm

Away Mode

The Away Mode feature on the ONE! App provides a seamless and secure way to arm your home quickly.

When Away Mode is activated, the thermostat automatically adjusts to the predefined temperature setting. Additionally, Away Mode initiates automatic photo capture of visitors at designated entrance areas.

You can customize the alarm settings on the Wall Pad, allowing you to set a delay for activation when leaving your suite and a timeframe for deactivating the alarm upon returning.

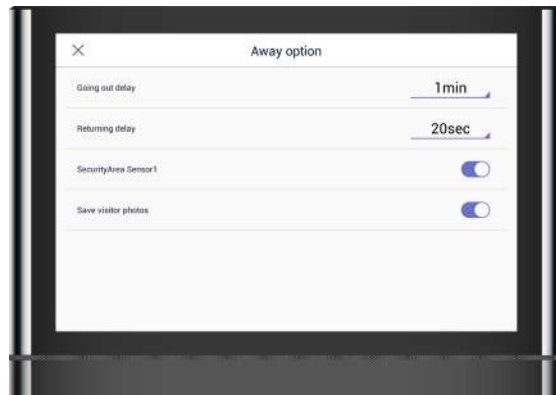
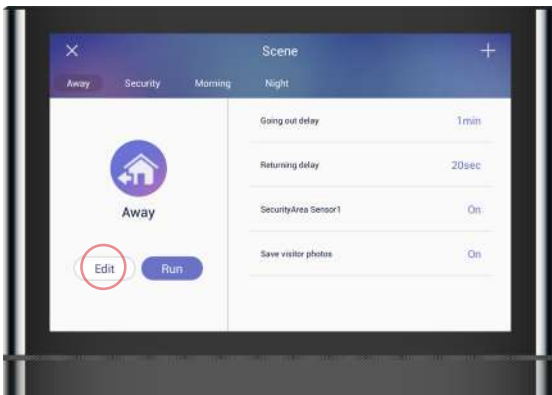
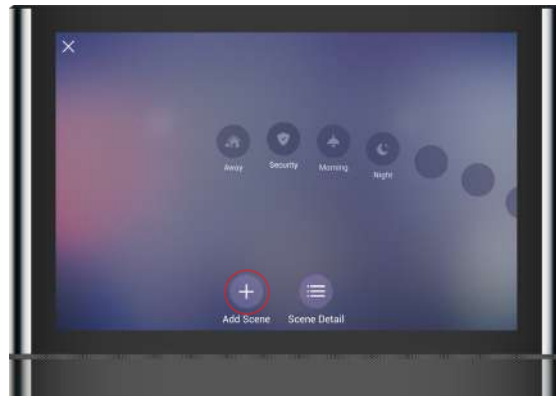
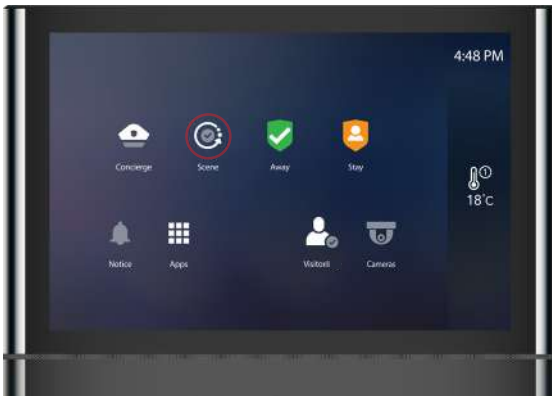
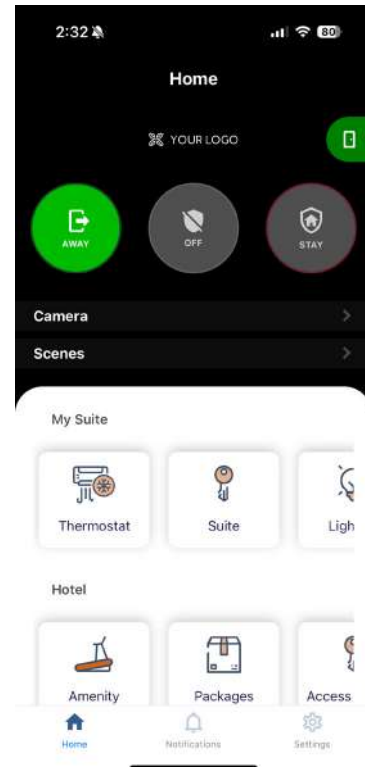

Stay Mode

Stay Mode is designed to enhance security while you're at home, providing peace of mind and a sense of safety within your residence.

To activate Stay Mode, simply tap the designated button on the app when you're home and want to enable the security system. While Stay Mode is active, the home screen will display a red indicator, signifying the active status. When Stay Mode is deactivated, the home screen will return to the 'OFF' state.

While Stay Mode is enabled, the thermostat in your suite will maintain the current temperature settings. For suites with motion sensors integrated into the alarm system, these sensors are bypassed, allowing you to move freely within your suite without triggering an alarm.

If the entry door is opened while Stay Mode is active, the suite alarm will immediately activate, notifying all paired smartphones and the concierge to ensure prompt attention and response.

- ⚠️ **If the alarm is triggered, you'll receive a notification on your smartphone and can dismiss the alarm; however, you'll need to enter your code on the wall pad to dismiss the alarm altogether.**

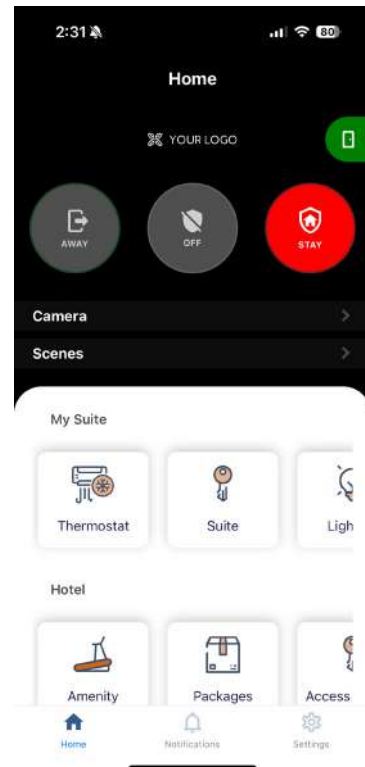

2.6 Lighting

The lighting feature allows you to customize and adjust your suite's lighting directly from the ONE! App or through the smart light switch, giving you full control over your space's ambiance.

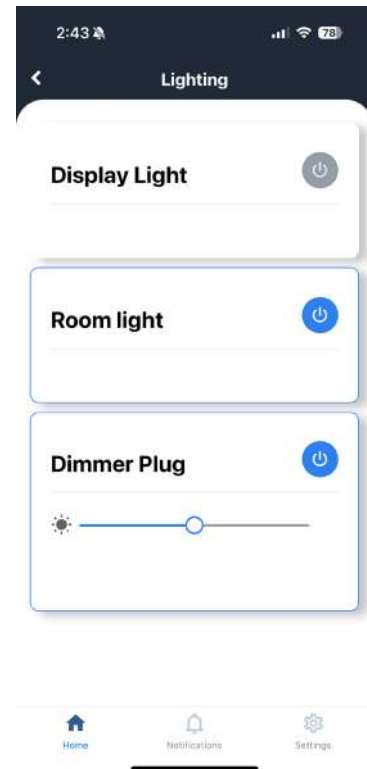

2.7 Cameras

The camera feature allows you to view designated community cameras for added peace of mind.

In the ONE! App, you can see a list of available cameras and view a live feed by selecting the desired camera image.

You can also access camera feeds directly from the Wall Pad in your suite. Please note that the image capture function is available only through the Wall Pad; this feature isn't supported on mobile devices. Any pictures or observations of suspicious activity can be captured exclusively using the Wall Pad.

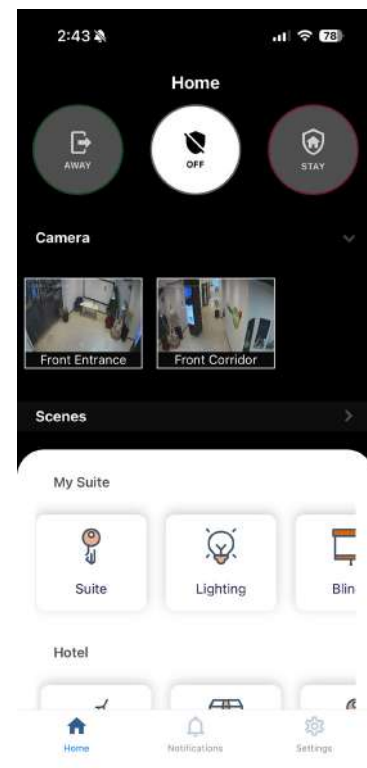

2.8 Scenes

The Scenes feature lets you automate your suite's atmosphere by selecting from pre-programmed settings you've created on your Wall Pad.

With Scenes, you can easily configure and manage your suite to suit different scenarios. A list of all your created Scenes is displayed, showing the specific settings for each. The default 'Stay' and 'Away' Scenes are always available and can't be removed, offering quick and convenient options for common situations.

⚠ Please note that Scenes can only be created on the Wall Pad. Once set up, these Scenes will automatically appear in the ONE! App, ready for you to activate with a tap.

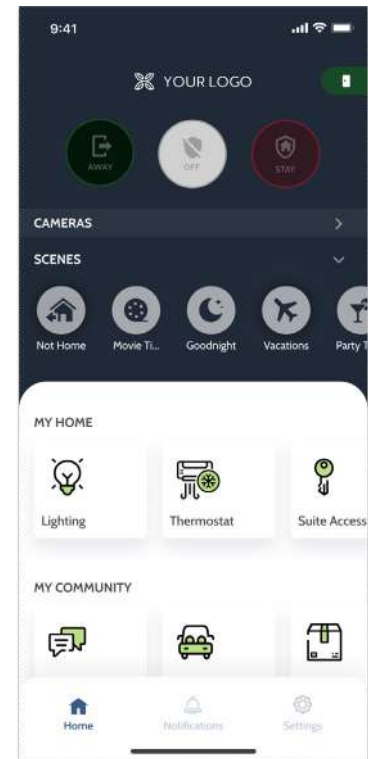

2.9 Amenity Booking

The amenity booking feature allows you to easily reserve building amenities for your personal use and enjoyment.

To make a new booking, simply click on '+,' to begin. Next, select the amenity you wish to book. Click Book Amenity, and you'll be directed to a page where you can select the date and other additional details.

Once you have entered your details, click Done to submit or Cancel to discard your booking. After confirming your booking, you'll see a notification that your request has been sent to the property manager for approval. If you're unable to complete the booking through the ONE! App, the property manager can assist you by making the booking on your behalf.

If you're unable to complete the booking through the ONE! App, the property manager can assist you by making the booking on your behalf.

⚠ Please note that payment for amenities is not handled through SmartONE, as payment functionality is not included.

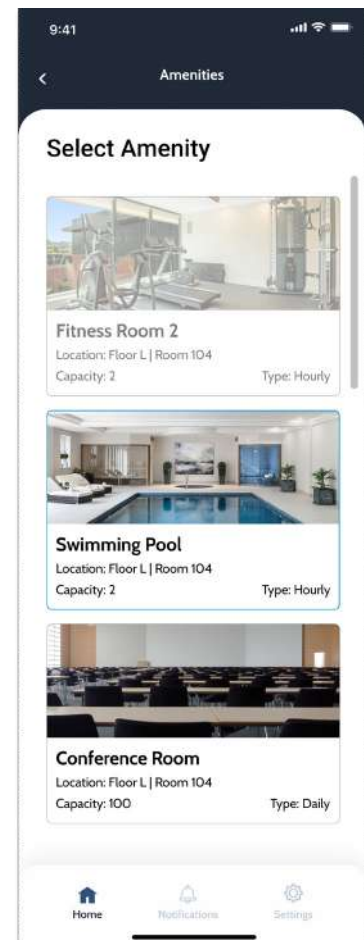

2.10 Ticket Service

The ticket service allows you to easily submit maintenance requests for your suite.

If you're unable to submit a ticket through the ONE! App, the property manager can raise a ticket on your behalf through the SmartONE Management Console. The ticket will then be reflected on your ONE! App.

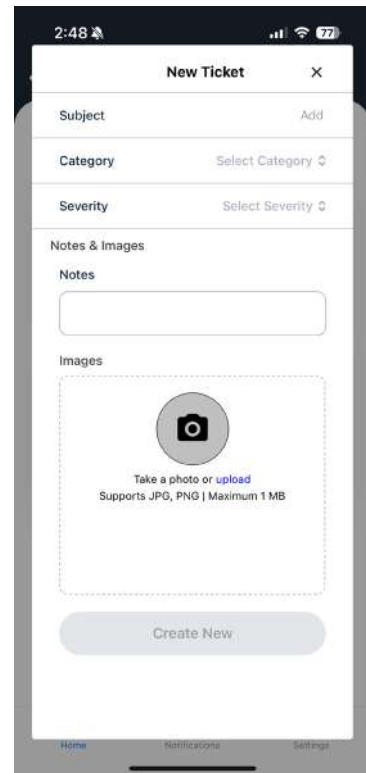

2.11 Settings and User Account

The Settings section in the ONE! App lets you configure your preferences. You can manage your personal information, select notification preferences, choose your preferred language, contact SmartONE support, review the terms and conditions, check the privacy policy, view connected hubs, and sign out.

You can also view your connected wall pads and either Move Out of Suite or Disconnect from Wall Pad.

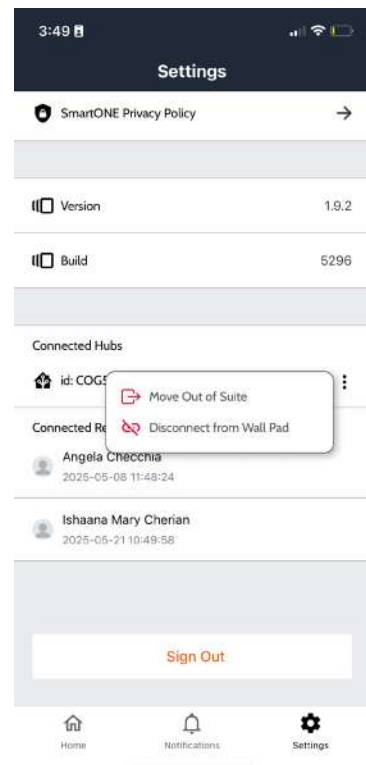
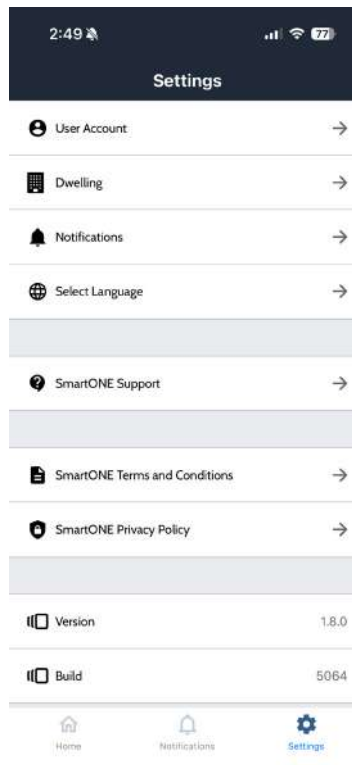

Digital Door Lock

The Digital Door Lock is a key component of your suite's smart living experience, designed for convenience and enhanced security. It features keypad entry, smart fob access, and integration with the ONE! App for remote unlocking. With customizable PIN codes, tamper alerts, and volume controls, managing access to your suite has never been easier. Be sure to select **high quality alkaline batteries** for optimal functionality.

3.1 CDL-200P Outside Body – Name & Function

	NAME	FUNCTION
①	Keypad	Enter numbers for registering or changing the password
②	Battery warning light	Lights up with an audible alarm when the battery charge is low
③	Smart fob input unit	Area where smart fobs are recognized to open the door
④	Outdoor Handle	Used to open or close the door from outside the suite
⑤	Emergency power terminal	If the battery is fully discharged, a 9V battery can be placed here to provide temporary power for access

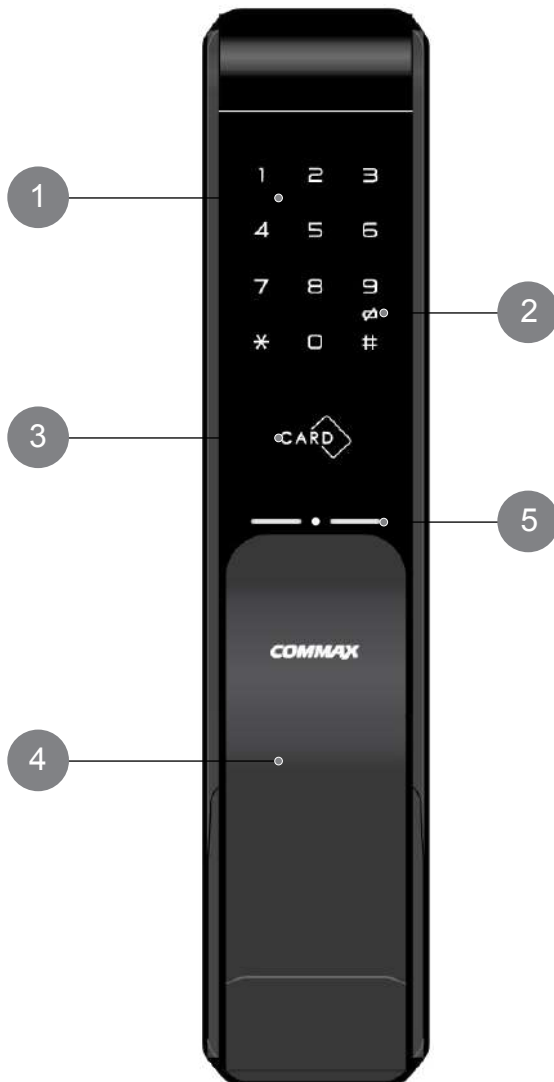

Model:
CDL-200P

CDL-200P Inside Body – Name & Function

	NAME	FUNCTION
①	Battery cover	Protects the batteries and the registration button
②	Interlocking pack	Receive (CDL-447, optional)
③	Registration button	Used for registering or changing passwords or smart fobs
④	Mortise	Attaches to the door's side and handles locking or closing
⑤	Dead bolt	Locks the door by securing it to the door frame
⑥	Latch bolt	Prevents the door from shaking
⑦	Alkaline AA Battery	Powers the door lock
⑧	Double lock button	Used to lock the door, preventing it from being opened from the outside
⑨	Indoor Handle	Used to open or close the door from inside the suite

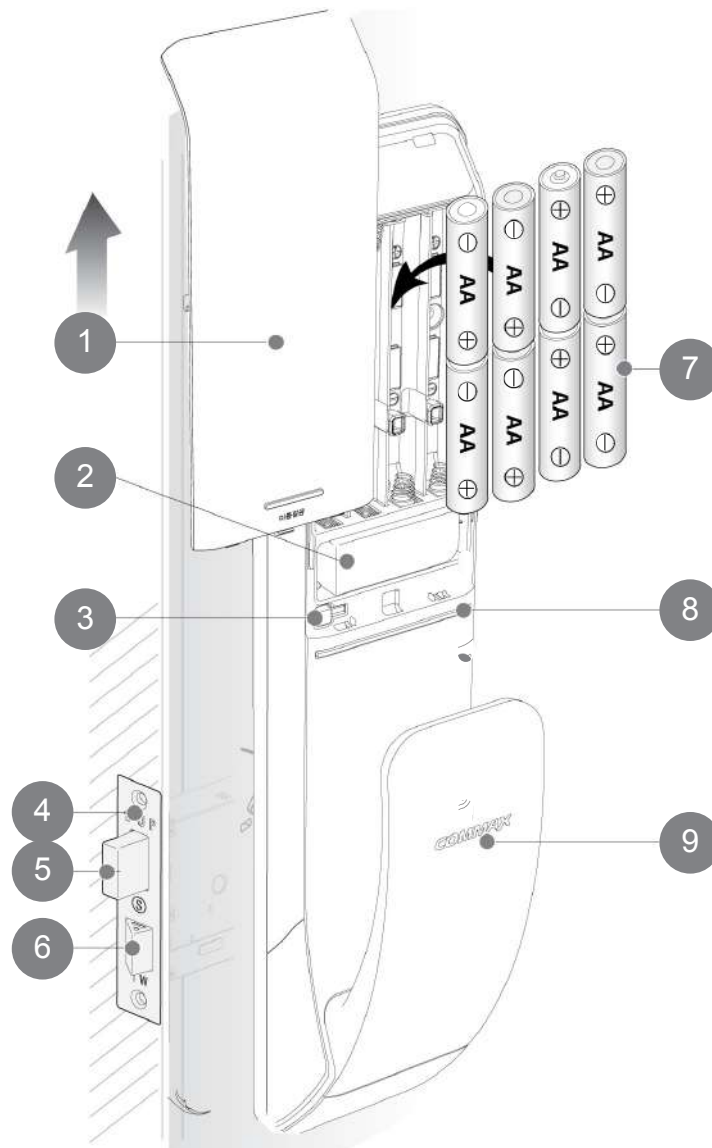

3.2 CDL-200L Outside Body – Name & Function

	NAME	FUNCTION
①	Keypad	Enter numbers for registering or changing the password
②	Battery warning light	Lights up with an audible alarm when the battery charge is low
③	Smart fob input unit	Area where smart fobs are recognized to open the door
④	Outdoor Handle	Used to open or close the door from outside the suite
⑤	Emergency power terminal	If the battery is fully discharged, a 9V battery can be placed here to provide temporary power for access

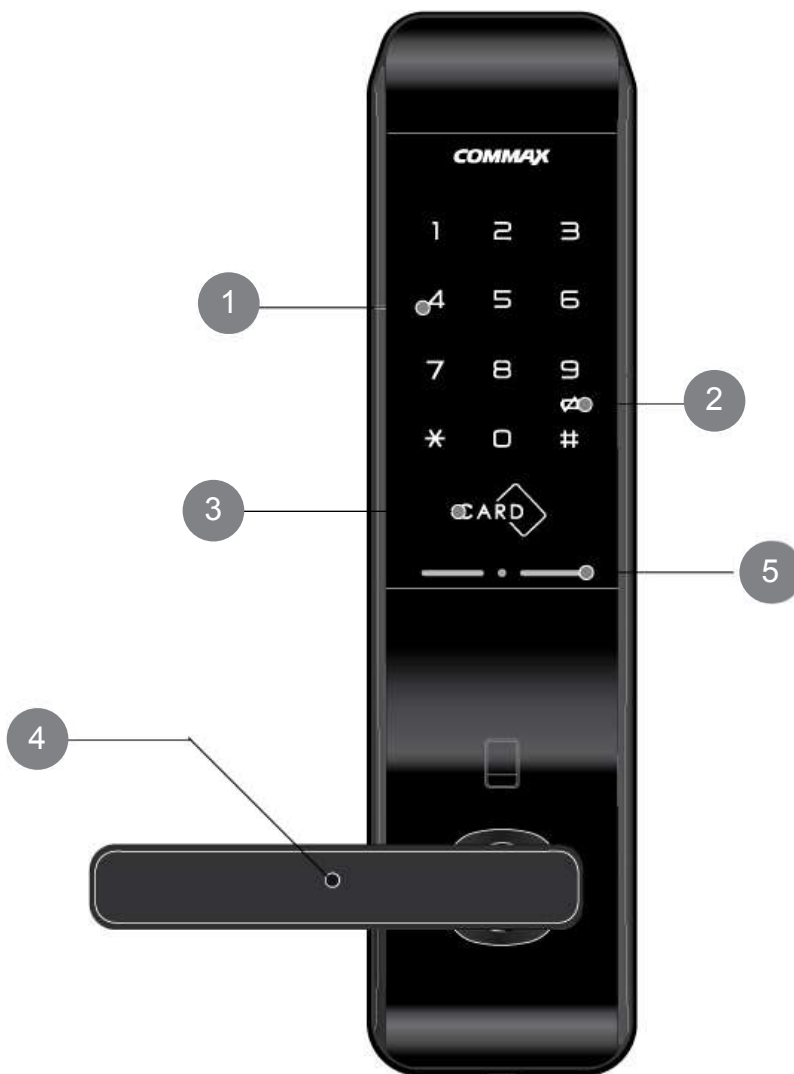

Model:
CDL-200L

CDL-200L Inside Body – Name & Function

NAME	FUNCTION
① Battery cover	Protects the batteries and the registration button
② Interlocking pack	Receive (CDL-447, optional)
③ Registration button	Used for registering or changing passwords or smart fobs
④ Mortise	Attaches to the door's side and handles locking or closing
⑤ Dead bolt	Locks the door by securing it to the door frame
⑥ Latch bolt	Prevents the door from shaking
⑦ Alkaline AA Battery	Powers the door lock
⑧ Double lock button	Used to lock the door, preventing it from being opened from the outside
⑨ Indoor Handle	Used to open or close the door from inside the suite

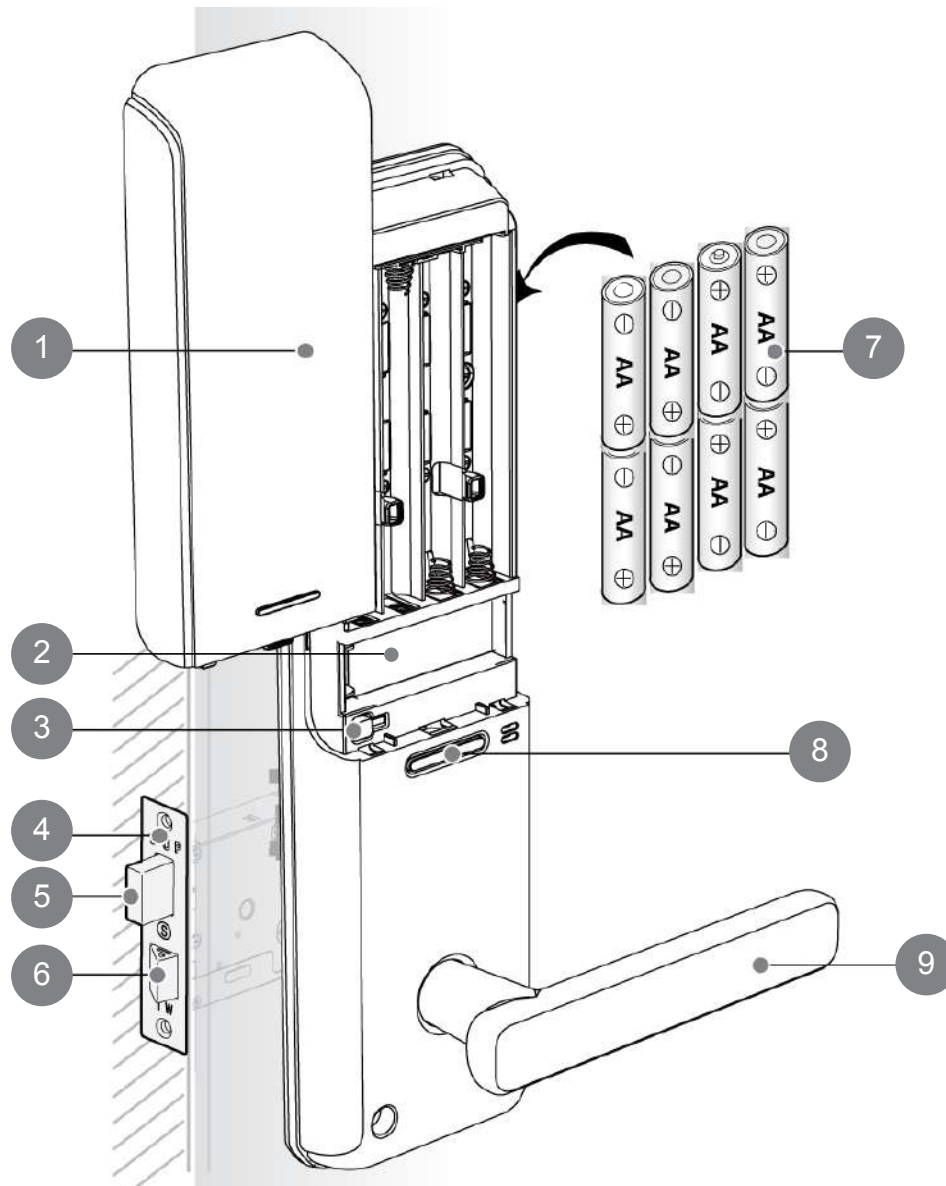

3.3 Locking/Double Locking Your Door from the Inside

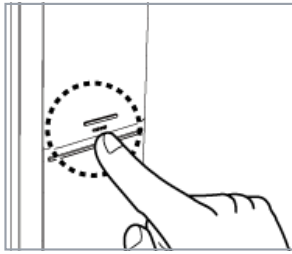

Inside

Locking your suite from the inside

Push the inside [double lock] button and the door will lock.

Note: Users with the correct PIN code or smart fob will still have access.

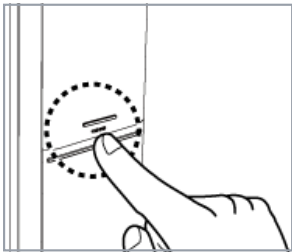

Inside

Double Locking your suite from the inside

Push the inside [Double Lock] button for 3 seconds to lock the door from all outside access (including those with a valid PIN code or smart fob).

Note: You can still exit the suite at any time. However, access to your suite is denied to all users unless they have the master smart fob. Anyone who is linked to the wall pad within the suite will also be able to access the door using their ONE! App.

Note: In case of an emergency, the master smart fob will be able to open the door whether the door is locked or double locked.

3.4 Locking your door from the outside

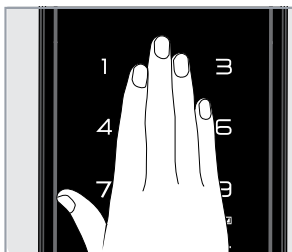

Outside

Locking your suite from outside

Touch the keypad when you leave your suite to lock the door.

3.5 Setting up Access - PIN Numbers

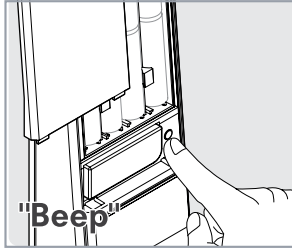

Inside

Step 1.

Open the door and remove the battery cover to access the Registration button. Push the button until you hear a 'beep' sound.

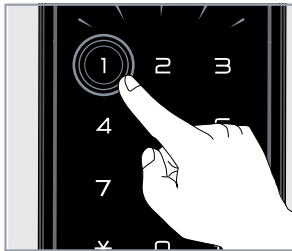

Outside

Step 2.

The keypad will illuminate. Push the button labeled 1.

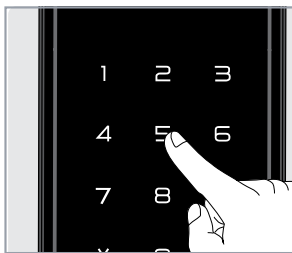

Outside

Step 3.

Enter a 4-to-12-digit private PIN code.

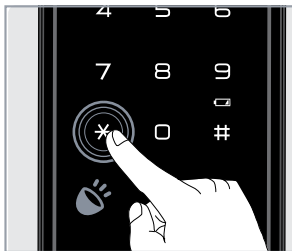

Outside

Step 4.

Push the [*] button. A 'beep' sound will confirm the registration. You can now enter additional PIN codes at this time and push [*] after each. Press the [*] button once more to complete the registration process of all PINs.

Note: Don't use consecutive numbers when registering your PIN code.

Note: For your security, adding a new PIN code will automatically delete all existing PIN codes. If you require multiple PIN codes, they must be registered during the same session.

- To add more PIN codes, repeat step 3 and 4 above, before the keypad lights turn off.
- You can register up to a maximum of four (4) PIN codes.

Note: If you have a biometric door lock, you may also register your fingerprint. Follow step 1 above. Then, press the number 4 on the keypad. Place and remove your finger on the fingerprint sensor four times. You may repeat the process for other fingers (up to 4 total), or simply press the registration button once more to complete the registration.

3.6 Setting Up Smart Fobs

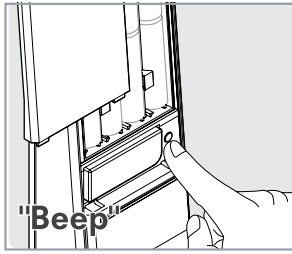

Inside

Step 1.

Open the door and remove the battery cover to access the Registration button. Push the button until you hear a 'beep' sound.

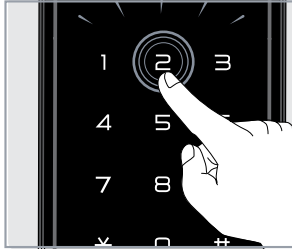

Outside

Step 2.

The keypad will illuminate. Push the button labeled 2.

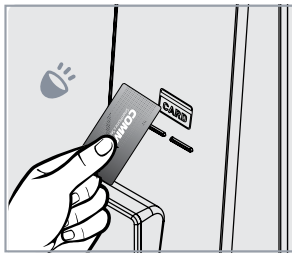

Outside

Step 3.

Hold smart fobs close to the reader. There will be a "Beep" sound when the registration is successful. You can register multiple smart fobs at this time. The registrations must occur before the keypad goes dim.

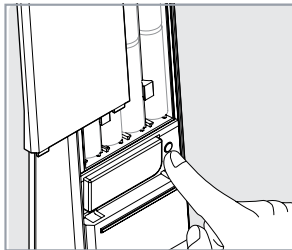

Inside

Step 4.

Push the Register button when you've finished registering all your smart fobs.

Note: Smart fobs are available from your Property Management team for an additional cost.

Note: Registering a new smart fob will wipe out all existing fobs. If you require multiple smart fobs, they must be registered during the same session.

- To add new smart fobs, repeat steps 3 to 4 above, before the keypad lights turn off.
- You can add up to thirty (30) smart fobs on your smart lock.

3.7 Delete All Smart Fobs

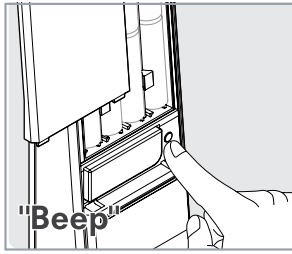

Inside

Step 1.

Open the door and remove the battery cover to access the Registration button. Push the button until you hear a 'beep' sound.

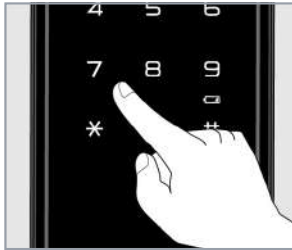

Outside

Step 2.

The keypad will illuminate.

Push the button labeled 7 to delete all smart fobs.



Outside

Step 3.

Press and hold the [#] button for 5 seconds to delete all registered smart fobs.

3.8 Unlocking Your Suite Door with Keypad

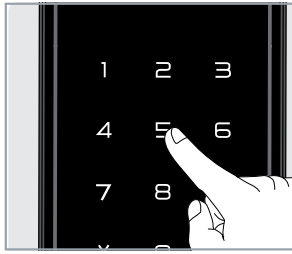

Outside

Step 1.

Touch the smart lock to light up the keypad.
Enter your PIN code.

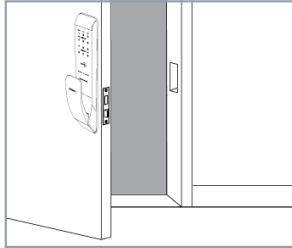

Outside

Step 2.

Push the [*] button. A 'beep' sound will
indicate the door has been unlocked.

 **Note:** As a safety precaution, you can input up to 20 numbers and as long as your PIN exists in the sequence of numbers, the smart lock will still open when you press [*].

3.9 Unlocking Your Suite Door with the ONE! App

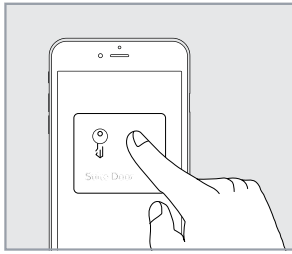

Outside

Step 1.

On the homepage of the ONE! app click on 'Suite Door'. Once the screen loads press the 'Unlock' button.

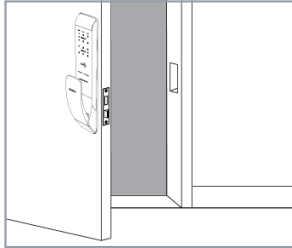

Outside

Step 2.

There will be a beep sound and the door will unlock.

3.10 Unlocking Your Suite Door with Smart Fob



Outside

Step 1.

Hold a registered smart fob close to the smart fob access point.

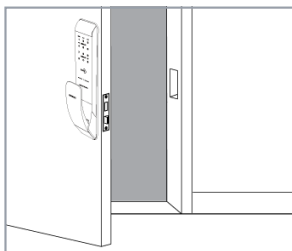

Step 2.

A 'beep' sound will confirm the door has unlocked.

3.11 Tamper Alarm

If there are five (5) failed attempts to enter a PIN code or use a smart fob, the smart lock will seize operation and sound an alarm for 1 minute.

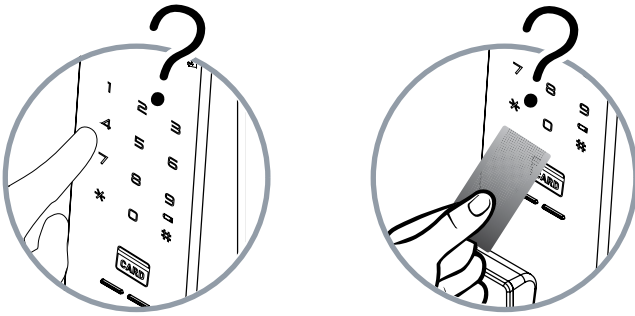

3.12 Battery Replacement Warning

When the high alkaline batteries run low, the battery icon light will illuminate, and the smart lock will emit a beeping sound. Be sure to select high quality alkaline batteries for optimal functionality.

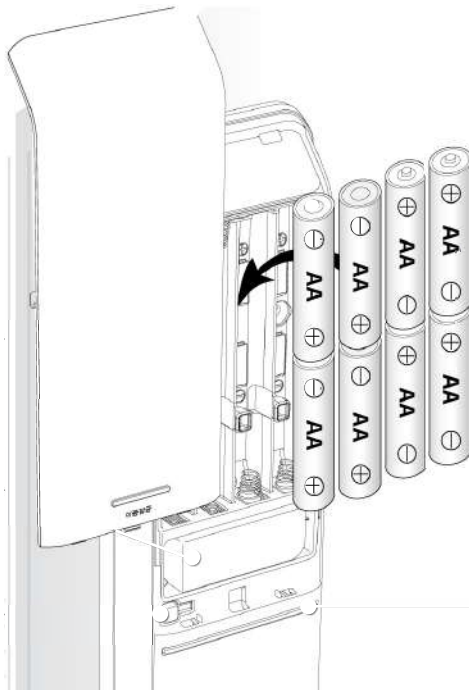

Note: Do not mix used batteries and new batteries. Please replace all batteries with new ones. Use only AA high alkaline batteries. Recommended batteries are Duracell, Energizers or HDXs.

3.13 Error Codes

The digital door lock will flash numerical error codes on the keypad.

The different error codes and their meanings are presented in the chart below.

FLASHING NO.	DESCRIPTION
1	Five or more incorrect PIN codes or smart fob attempts; alarm sounds and lock disables for 1 minute
2	PIN number or smart fob registration failed
3	Maximum quantity of PIN codes have been stored
4	Deadbolt is jammed or blocked by a foreign object
5	Tamper alert; someone is trying to force the lock
6	Unregistered PIN code was used
7	Unregistered FOB was used.
8	Fire alert; the smart lock is sensing a high temperature in the suite
9	Dual lock activated from inside

3.14 Battery Failure - Backup Power

If the batteries in the smart lock are completely discharged, use a 9V battery as shown in the diagram below to temporarily power the smart lock.

Step. 1

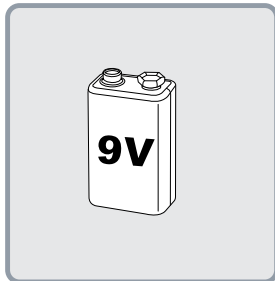

Get a 9V battery.

Step. 2

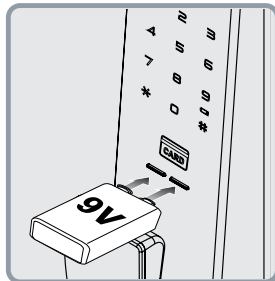

Hold it on terminals.

Step. 3



Input your passcode, tap your fob or use your ONE! App while still holding the battery to the terminals, to open your door.

Directly After:

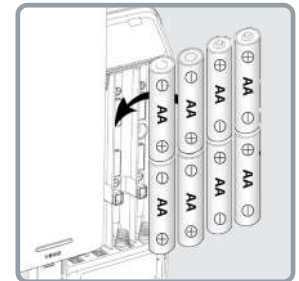

Please replace all the old batteries to new, high alkaline ones, such as Energizers, HDX or Duracells immediately.

Note: The polarity of the battery doesn't matter; it can be placed either way on the contacts.

3.15 Adjust Digital Door Lock Sound Volume

To adjust the volume of sounds made by the digital door lock, follow the below steps:

Note: The door must be locked, so you need to be outside your suite to adjust the volume setting.

Step. 1



Enter your PIN code

Step. 2

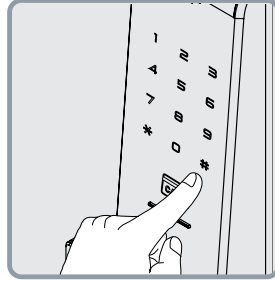

Press the [#] button

Step. 3

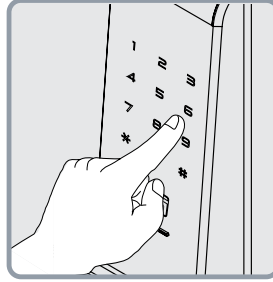

Press **6** to lower the volume or **3** to raise the volume

Step. 4



Press [*] to complete the process

Additional Support

If your suite's wall pad or smart lock isn't working as expected, follow these steps to get assistance:

- **SmartONE Support:** Can't reach your property manager? Simply tap the SmartONE Support link in your ONE! App for additional resources and direct assistance.

